

Plan 54

Description: Plan 54 is an external system supplying clean BARRIER fluid to a dual seal “arrangement 3” at greater pressure than the process pressure being sealed. Pressure and circulation are provided for by an external pump or pressure system.

Objective: Same as Plan 53A and will provide constant pressure and flow through circulation system.

Advantages: Same as Plan 53A but provides excellent circulation and cooling. Can be used on multiple seals to reduce cost. The barrier fluid enters the seal and exits in a once in and once out fashion.

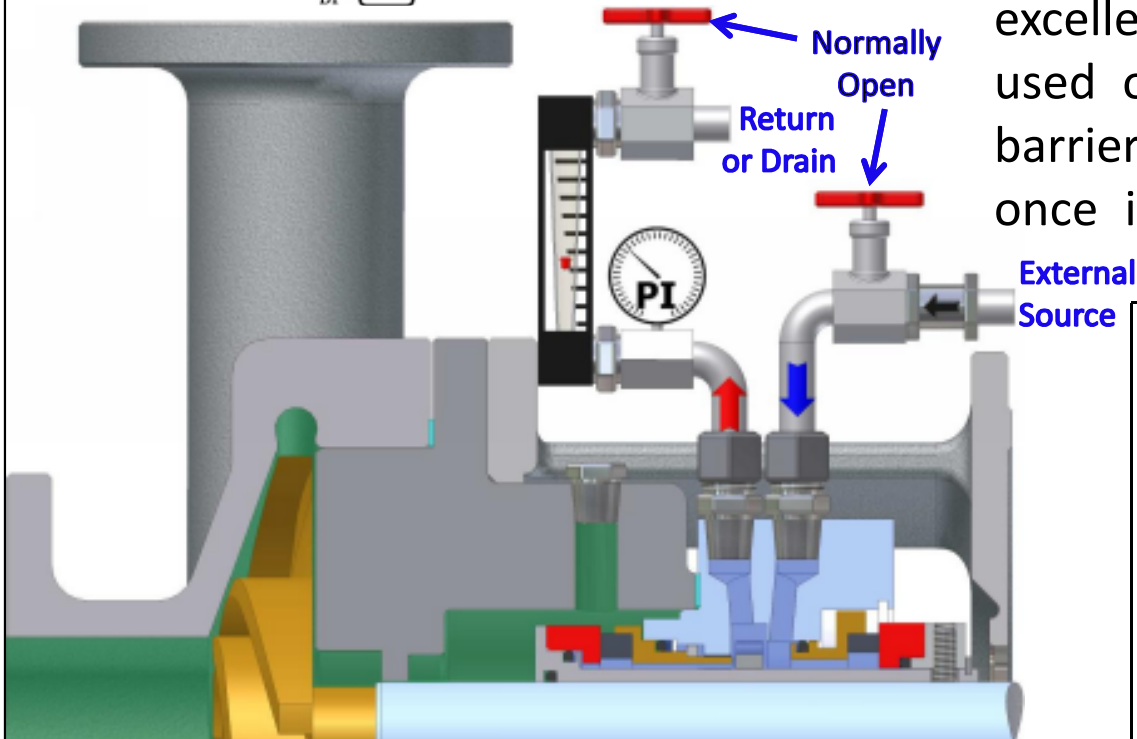
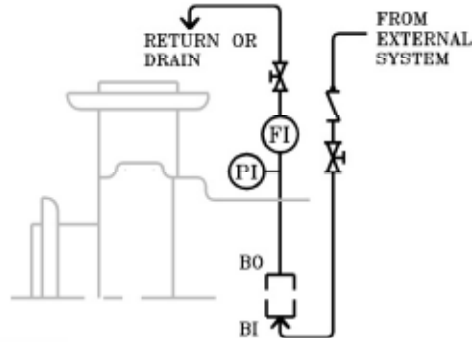

Plan 55*

Plan 55 is similar to Plan 54 except the system supplying clean BUFFER fluid is at less pressure than the process pressure being sealed, to a dual seal “arrangement 2”. No process contamination and improved cooling over Plan 52.